

# PEOPLES STEEL MILLS LIMITED

Manghopir, Karachi.

## REQUEST FOR QUOTATION



M/s.

RFQ NO. SSAMC/BU-1/LP-33/PR-1366/1561

ISSUED ON 28-AUG-23

DUE ON 07-SEP-23

Dear Sirs,

We invite you to quote for the following material on F.O.R PSM site basis inclusive of all Government taxes and levies on the terms and conditions attached herewith valid for 45 days. Your offer must reach the office of the undersigned by the date mentioned above.

S. NO.	DESCRIPTION	QUANTITY	RATE
1	CRANE CURRENT COLLECTOR.MATERIAL: CORBON.SIZE: AS PER DRAWING	24 NOS	
2	CRANE BUS BAR.RATING: 200 AMP.VOLTAGE: 400V AC.MATERIAL: ALUMINIUM.SIZE: LENGTH: 15 FT.AS PER DRAWING	130 MTR	
3	CRANE BUS BAR JOINTS.MATERIAL: ALUMINIUM.AS PER DRAWING	24 NOS	
4	BUS BAR JOINT COVER.MATERIAL: PLASTIC..AS PER DRAWING	50 NOS	
5	CRANE CALBE TROLLY (A) COMPLETE.MATERIAL: STEEL AS PER DRAWING	36 NOS	
6	CRANE CALBE TROLLY (B) COMPLETE.MATERIAL: STEEL AS PER DRAWING	36 NOS	
7	CRANE CONDUCTOR BUS BAR HANGER CLAMPS.4 POLES.AS PER DRAWING	36 NOS	
8	CRANE BUS BAR COLLECTOR ARM.RATING: 200 AMP.VOLTAGE: 400V AC.AS PER DRAWING	8 NOS	
9	CRANE DISK BRAKE.(INTORQ BREAK).DIMENSION: AS PER DRAWING	1 SET	

**NOTE** : All items detail are attached with PR

Offer on F.O.R. Basis Must Be Sent To the Attention of Head (Procurement) On Fax No. (92 21) 36770112, 5206764 or By Courier Service at the Factory Address PABX No (92 21) 36770126-27-28 Procurement Direct No. (92 21) 36770121 or email: ahsan@psmltd.com, nauman@psmltd.com .

PSM will take delivery of order material from supplier premises having value upto Rs 20,000/- through own arrangement.



**Yours Sincerely**  
For **PEOPLES STEEL MILLS LIMITED**

**Deputy General Manager**  
**(PROCUREMENT)**

## FINISHING MILL CRANE ITEMS

S NO	DESCRIPTION	QTY	ESTIMATED PRICE	REMARKS
1	CRANE CURRENT COLLECTOR CORBON (AS PER SAMPLE) DRAWING AND PICTURE & MATERIAL DATA SHEET ATTACHED	24 pic	1000/PIECE	
2	CRANE BUS BAR RATING 200 A / 400V MATERIAL ALUMINIUM LENGTH 15 FT AS PER DRAWING AND PICTURE	130 METER	1500/MTR	
3	BUS BAR JOINTS MATERIAL ALUMINIUM (AS PER SAMPLE) DRAWING AND PICTURE ATTACHED	24 pic	400/PIECE	
4	BUS BAR JOINT COVER (PLASTIC) DRAWING AND PICTURE ATTACHED	50 pic	<b>350/PIECE</b>	
5	CRANE CALBE TROLLY(A) (COMPLETE ) MATERIAL STEEL(AS PER SAMPLE) DRAWING AND PICTURE ATTACHED	36 PIEC	<b>2500/PIECE</b>	
6	CRANE CALBE TROLLY(B) (COMPLETE ) MATERIAL STEEL(AS PER SAMPLE) DRAWING AND PICTURE ATTACHED	36 PIEC	<b>2500/PIECE</b>	
7	CONDUCTOR BUSBAR HANGER CLAMPS 4 POLES	36 PIEC	<b>400/PIECE</b>	

8	BUS BAR COLLECTOR ARM 200A /400V	8 PIEC	6500/PIECE			

1

**CURRENT COLLECTOR CORBON**

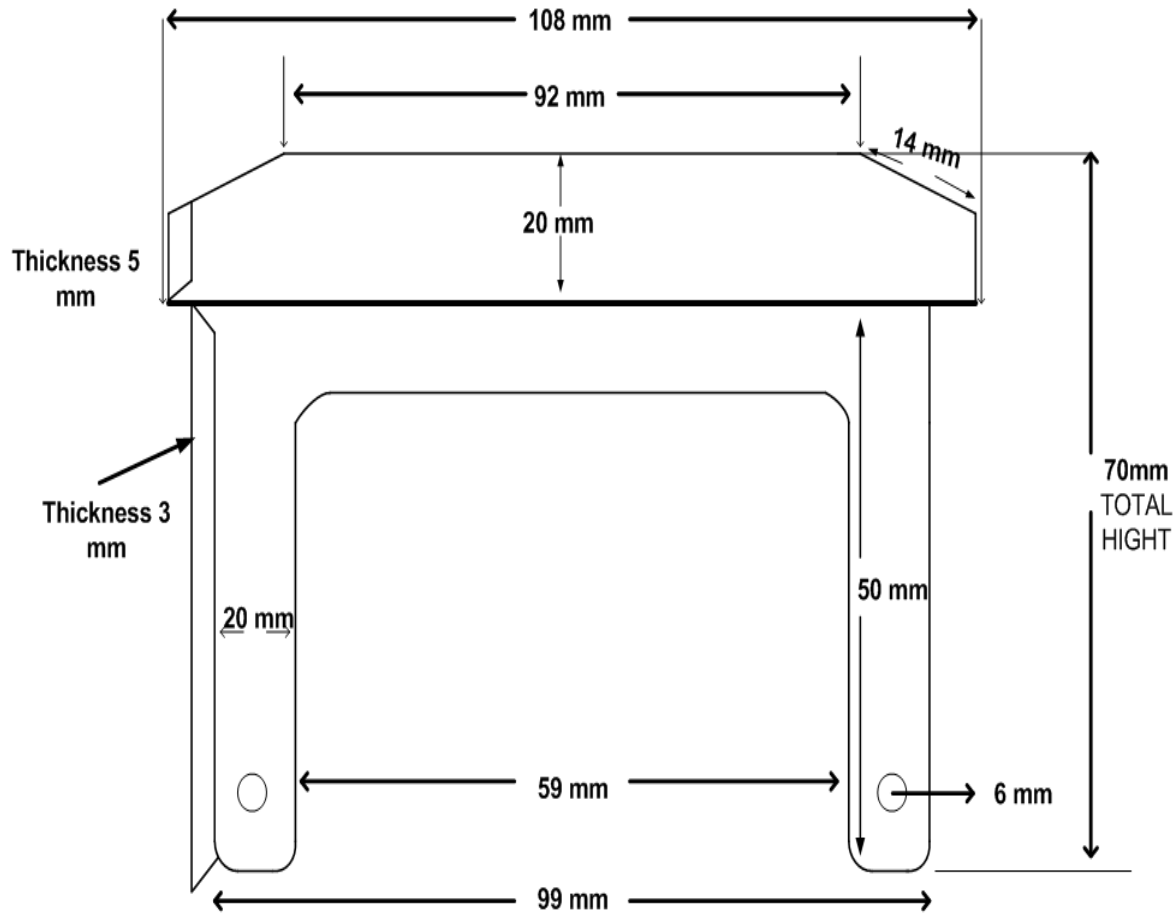

2

BUS BAR

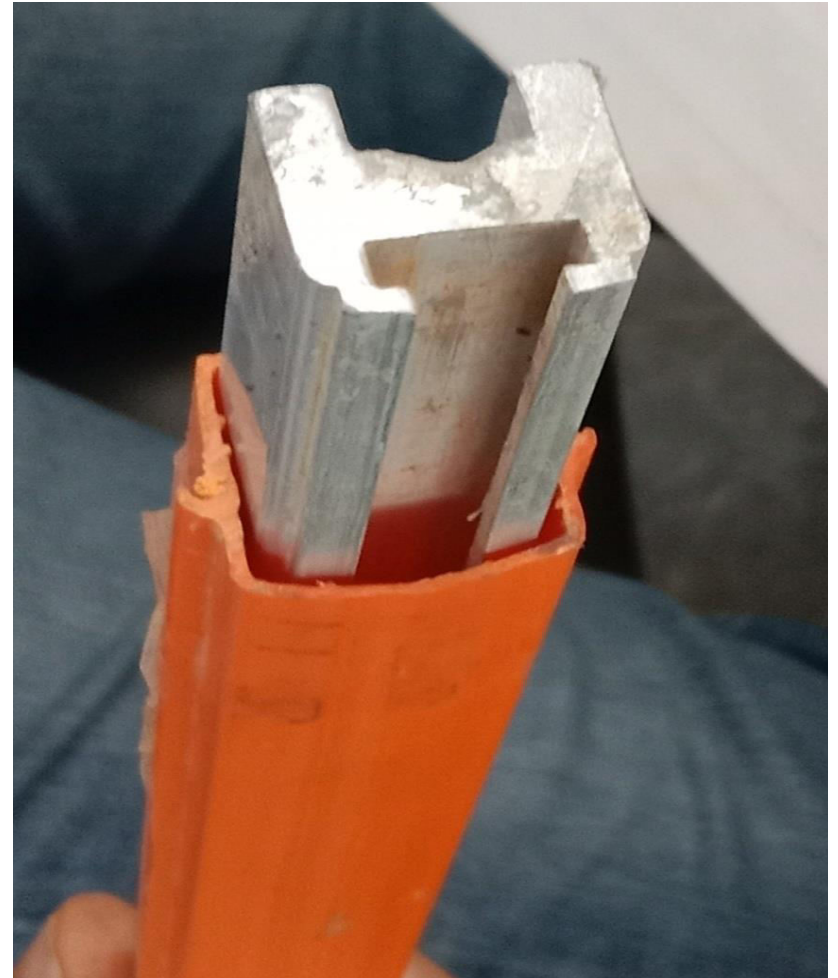
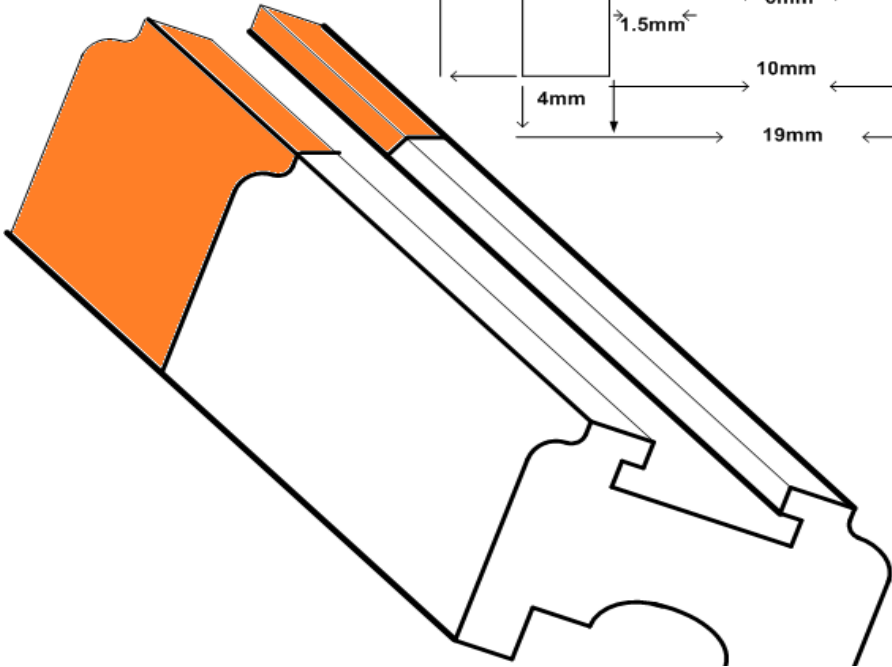
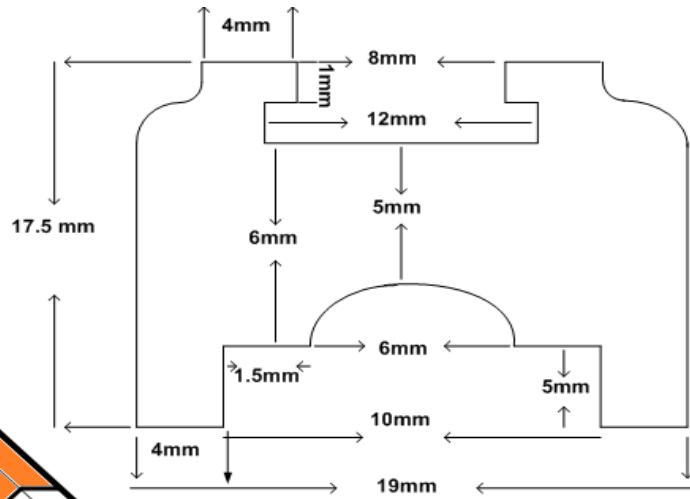



### 3 BUS BAR JOINTS WITH PLASTIC COVER

PLASTIC COVER

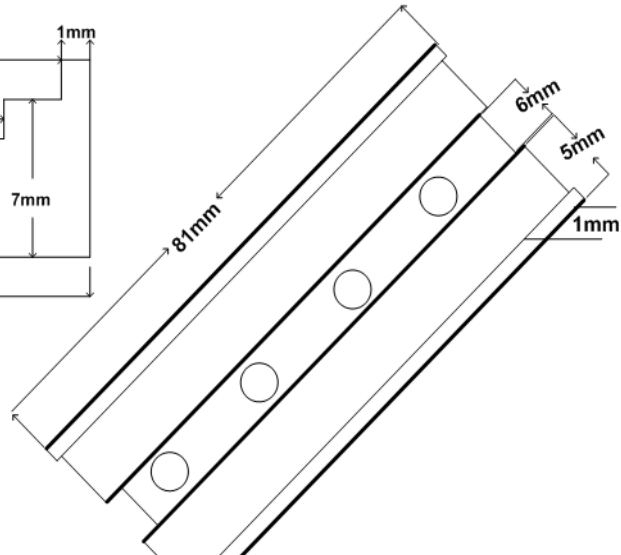
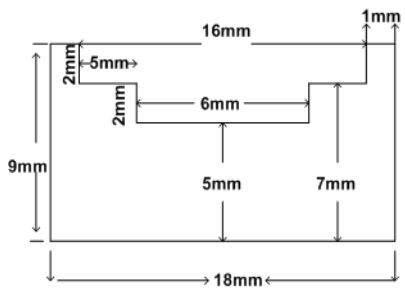
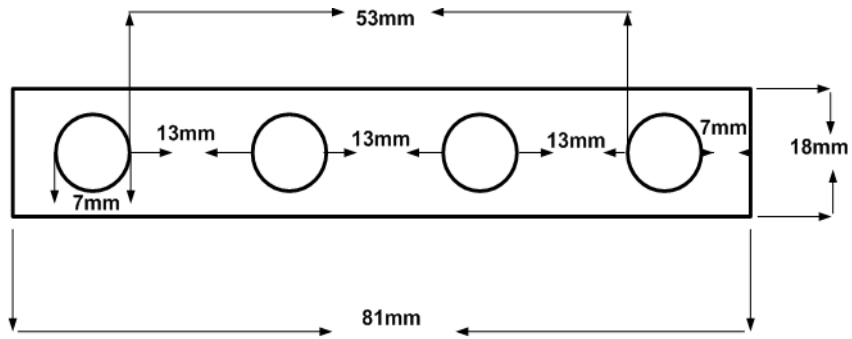



5 & 6

### CALBE TROLLY ( Complete Set-A)

TROLLY A

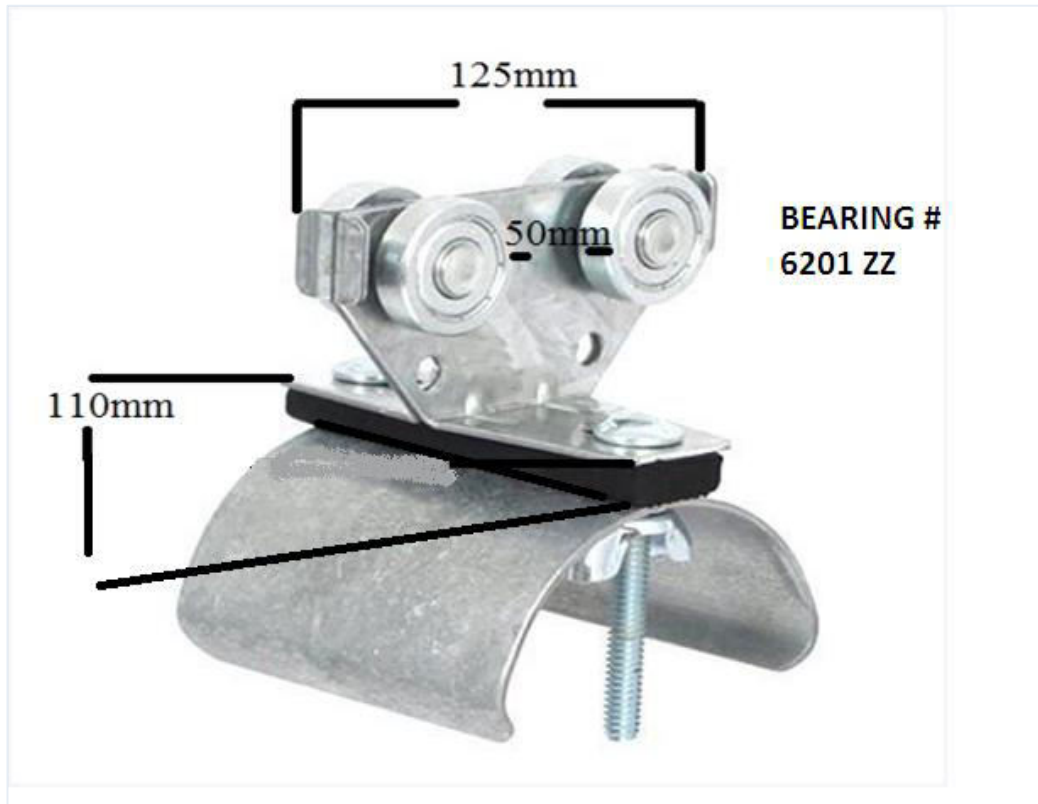

### CALBE TROLLY ( Complete Set-B)

TROLLY B

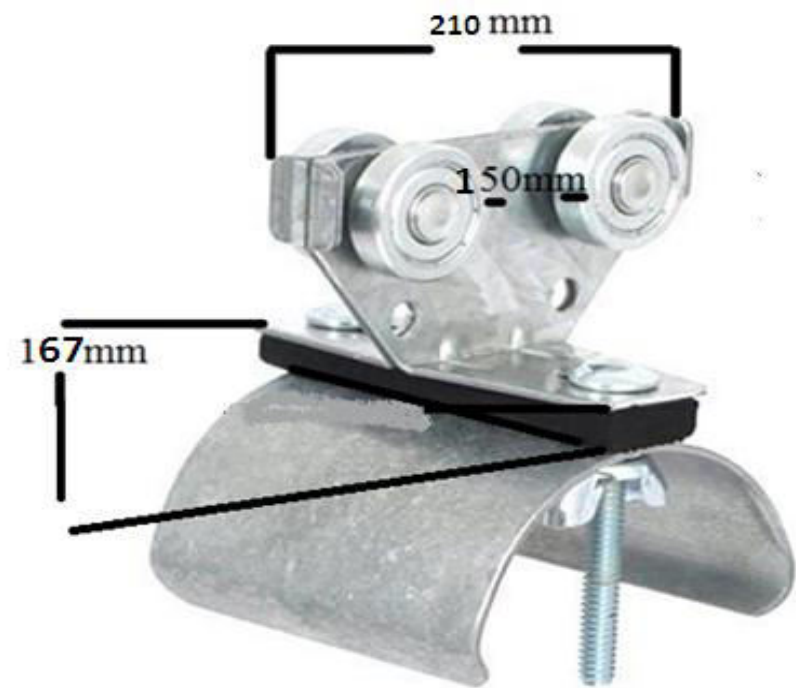

7 Conductor busbar hanger

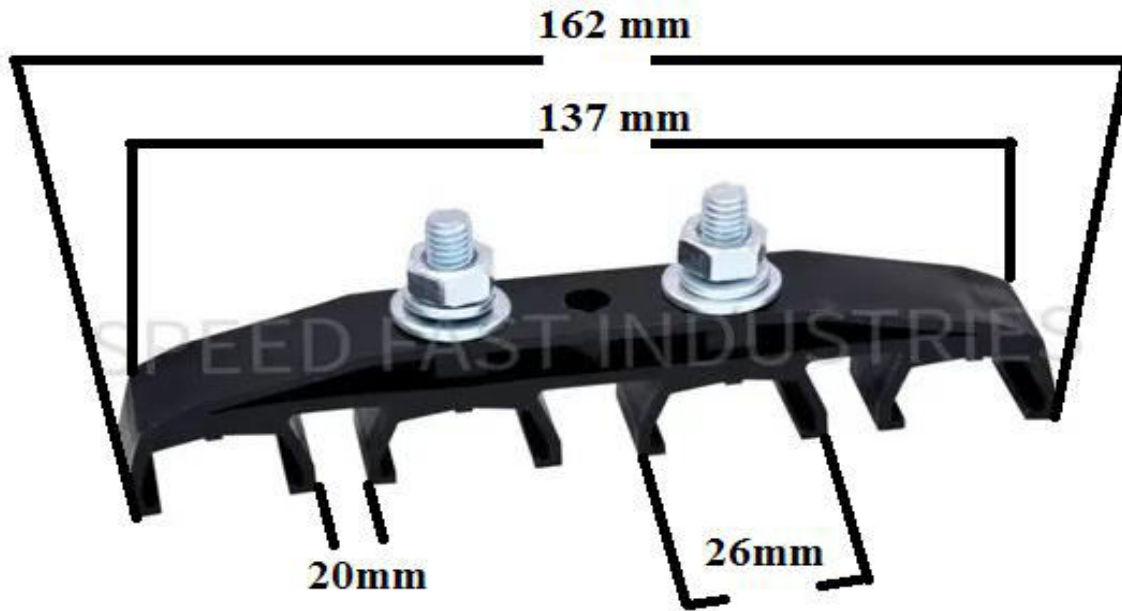

8 BUS BAR CURRENT COLLECTOR











CURRENT COLLECTOR CORBON  
AS PER DRAWING











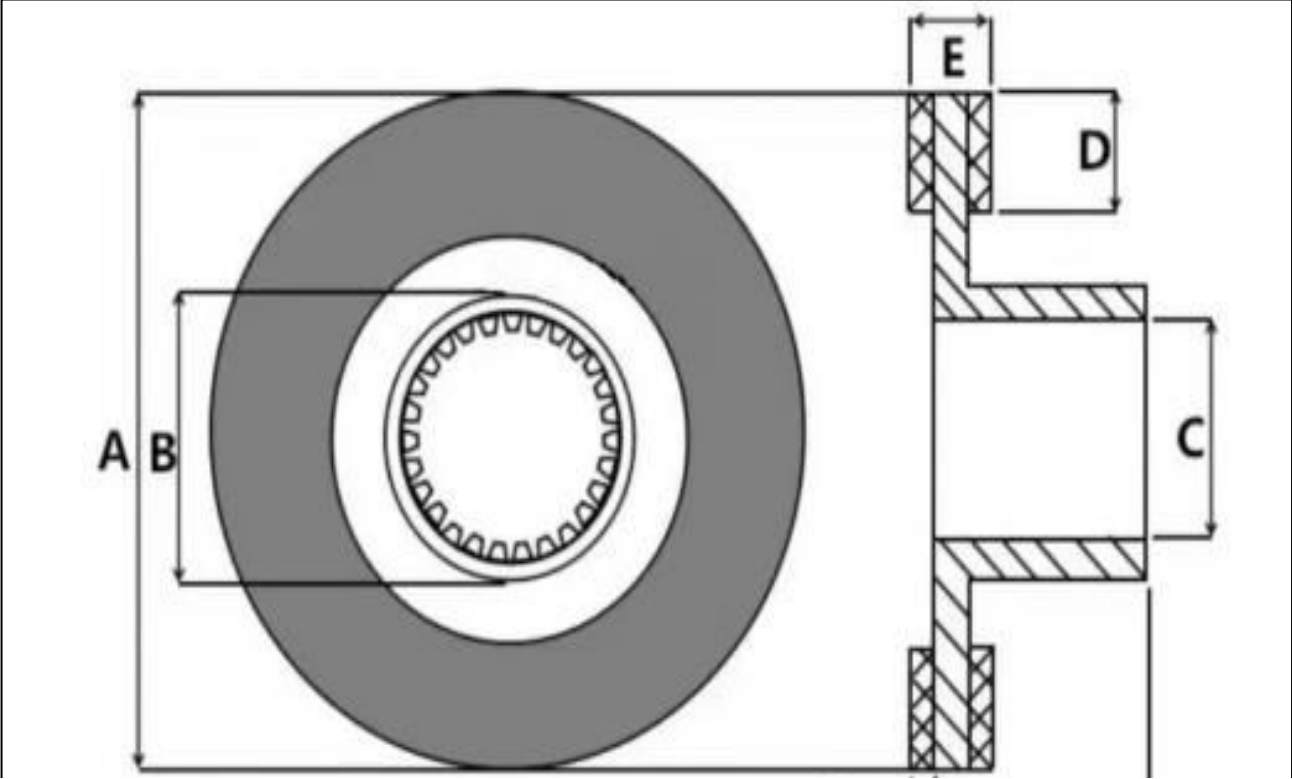



**DISK BRAK (INTORQ BREAK )**

DISK #1 SIZE (AS PER SAMPLE)

TOOTH	A	B	C	D	E	F	G	QTY	EST COST
32	174	76	65	33	14	4	35	1	4000

DISK #2 SIZE (AS PER SAMPLE)

TOOTH	A	B	C	D	E	F	G	QTY	EST COST
30	124	54	65	24	14	4	35	1	4000

DISK #3SIZE (AS PER SAMPLE)

TOOTH	A	B	C	D	E	F	G	QTY	EST COST
28	150	66	65	22	14	4	35	1	4000

**DIMENSION DRAWING**

