

PEOPLES STEEL MILLS LIMITED

Manghopir, Karachi.

REQUEST FOR QUOTATION



M/s.

RFQ NO. PSM/LP-22/PR-21352/21931

ISSUED ON 19-AUG-23

DUE ON 05-SEP-23

Dear Sirs,

We invite you to quote for the following material on F.O.R PSM site basis inclusive of all Government taxes and levies on the terms and conditions attached herewith valid for 45 days. Your offer must reach the office of the undersigned by the date mentioned above.

S. NO.	DESCRIPTION	QUANTITY	RATE
1	EXPENSION BELLOWS SIZE DIA 60 X 50 MM, LENGTH 810 MM MAX, 160 MM MINIMUM, MATERIAL NEOPREN CLOTH, DRG NOJ- 443192/306Y10252 ATTACHED	4 NOS	

NOTE : 1. PSM will take delivery of ordered material from supplier premises having value upto Rs. 20,000/- through own arrangement.

2. Offer must be sent to the attention of Head (Procurement) on Fax no. 36770112, 35206764 or by courier service at the factory address. Procurement Direct No. (92 21) 36770121.
Email: muneeb.local@psmltd.com & shayan_proc@psmltd.com

3. Delivery lead time should be within 10 to 15 days after receipt of Purchase Order.

4. Payment will be made within 45 days after acceptance of material at PSM site.

Yours Sincerely
for PEOPLES STEEL MILLS LIMITED

6 HOLE-14DRILL THRU
ACCESSORIES
M12 X 25L BOLT
& SPRING WASHER

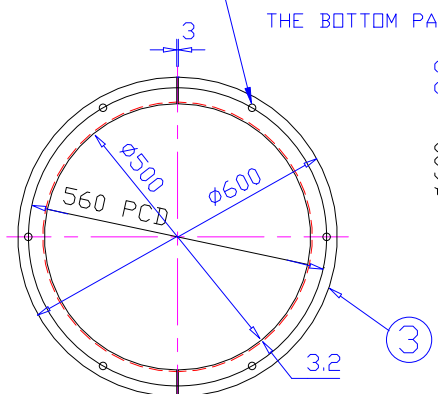

THE BOTTOM PART

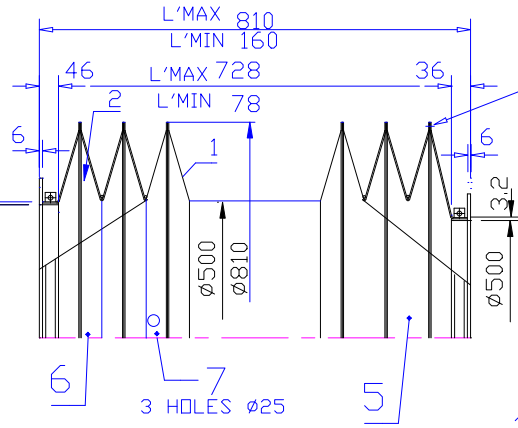

3 HOLES ϕ 25

SEW BY MACHINE

THE UPPER PART

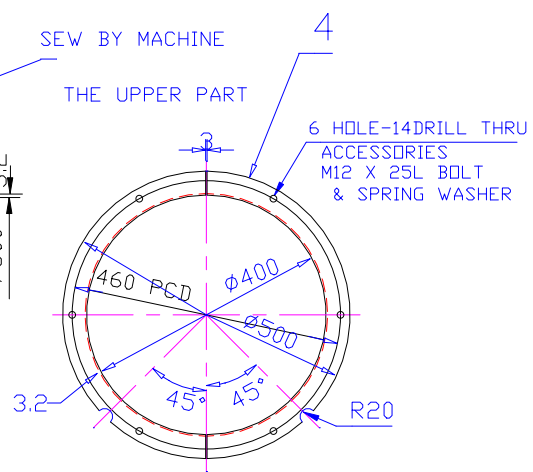

6 HOLE-14DRILL THRU
ACCESSORIES
M12 X 25L BOLT
& SPRING WASHER

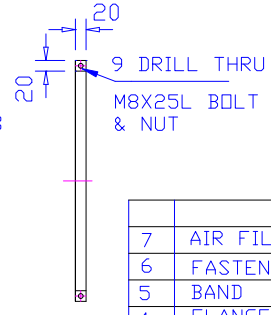
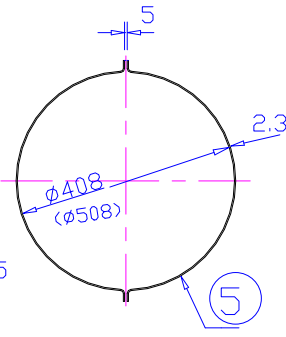
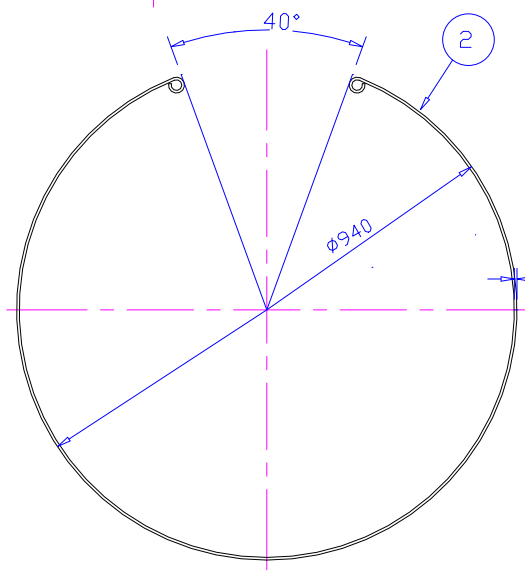

NO.	DESCRIPTION	MATERIALS	QTY.
7	AIR FILTER	NYLON	03
6	FASTENER	BS-Bm	01
5	BAND	SS-41P	02
4	FLANGE	SS-41P	01
3	FLANGE	SS-41P	01
2	RING(INSIDE)	SWPA	06
1	BODY	Neopren Cloth	01

L'MAX 728
L'MIN 78
PITCH 146
PLEATS 5

SCALE: 1:10	MAT: Neopren Cloth	Drw. No. 306Y10252
DATE 16-7-94	Title: 2-HIREVERISING MILL	
DRAWN BY AKBAR		
CHECKED BY TARIQ HASHMI		
APPROVED BY NOMAN AZIZ		