



M/s.

RFQ NO. SPM/BU-2/LP-44/PR-1424/1996

ISSUED ON 26-SEP-23

DUE ON 02-OCT-23

Dear Sirs,

We invite you to quote for the following material on F.O.R PSM site basis inclusive of all Government taxes and levies on the terms and conditions attached herewith valid for 45 days. Your offer must reach the office of the undersigned by the date mentioned above.

S. NO.	DESCRIPTION	QUANTITY	RATE
1	BUSH SMALL ROLL MUFF (PIERCER) SIZE: 108 x 100 x 125 MM, MATERIAL: PB2, FINISH DIMENSION AS PER DWG 200751 ITEM-2. FINISH WT 7.34 KG.	6 NOS	
2	BUSH DRIVE MUFF (PIERCER) SIZE: DIA 150 MM, LENGTH 145 MM, MATERIAL: PB2, FINISH DIMENSION AS PER DWG 200751 ITEM-3. FINISH WT 13.95 KG.	6 NOS	
3	SLIPPER SMALL ROLL (PIERCER) SIZE: 340 x 170 x 52 MM, MATERIAL: PB2, FINISH DIMENSION AS PER DWG 200753 ITEM-1. FINISH WT 24.5 KG.	6 NOS	
4	BUSH LARG ROLL MUFF (PIERCER) SIZE: 145 x 120 x 130 MM, MATERIAL: PB2, FINISH DIMENSION AS PER DWG 200755 ITEM-2. FINISH WT 15 KG.	3 NOS	

NOTE : 1. Delivery lead time should be within 15 days after receipt of Order.

2. Payment will be made within 45 days after acceptance of material.

3. Offer must be sent to Attention of Head (Procurement) through Fax / Post / or Email:
m.naeem@psmltd.com, farrukh.khan@psmltd.com

Yours Sincerely
For **PSM Seamless Pipe Mill.**

Deputy General Manager
(PROCUREMENT)

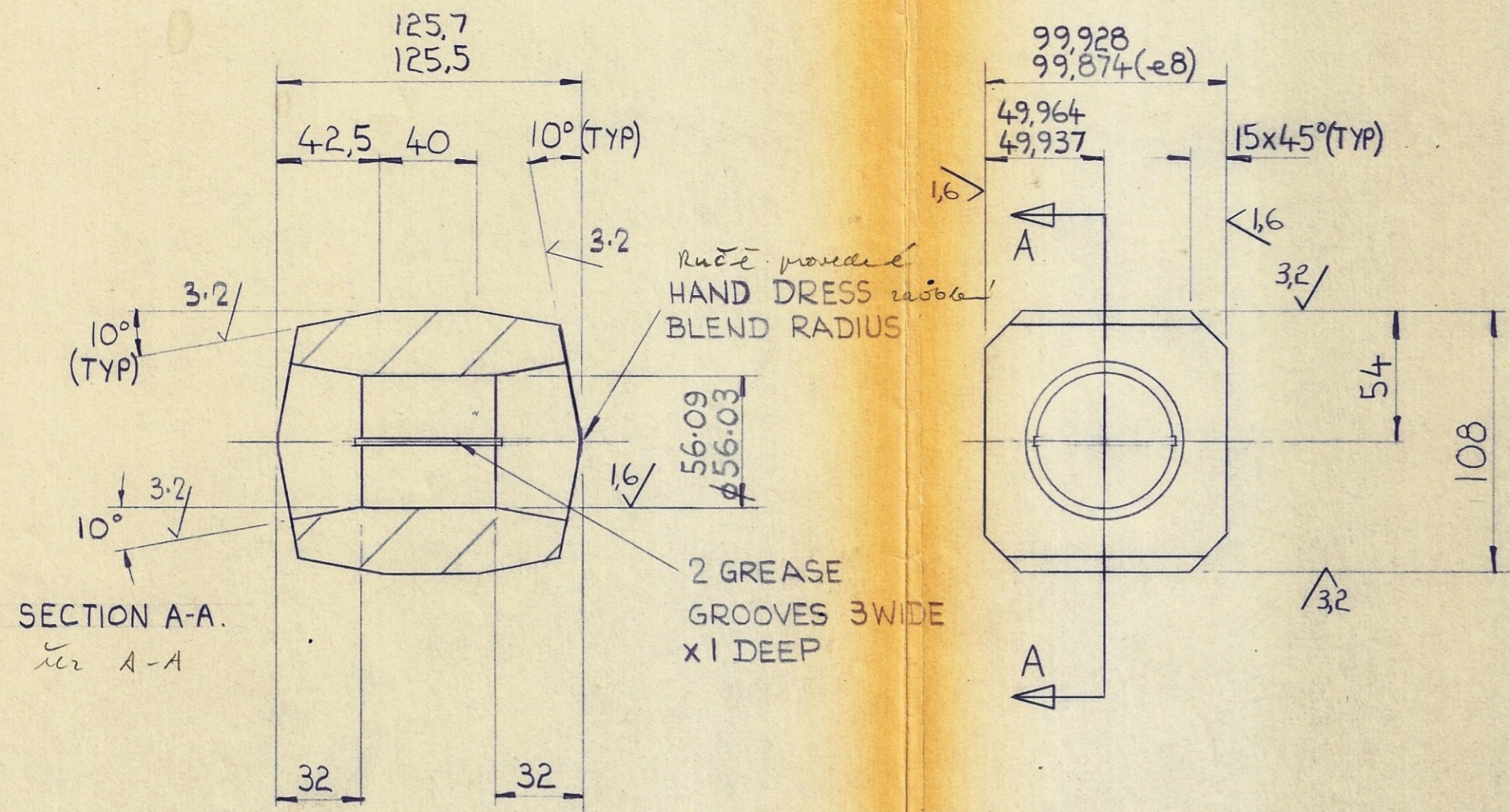

SCALE 1:2.5.

REMOVE ALL SHARP CORNERS

2

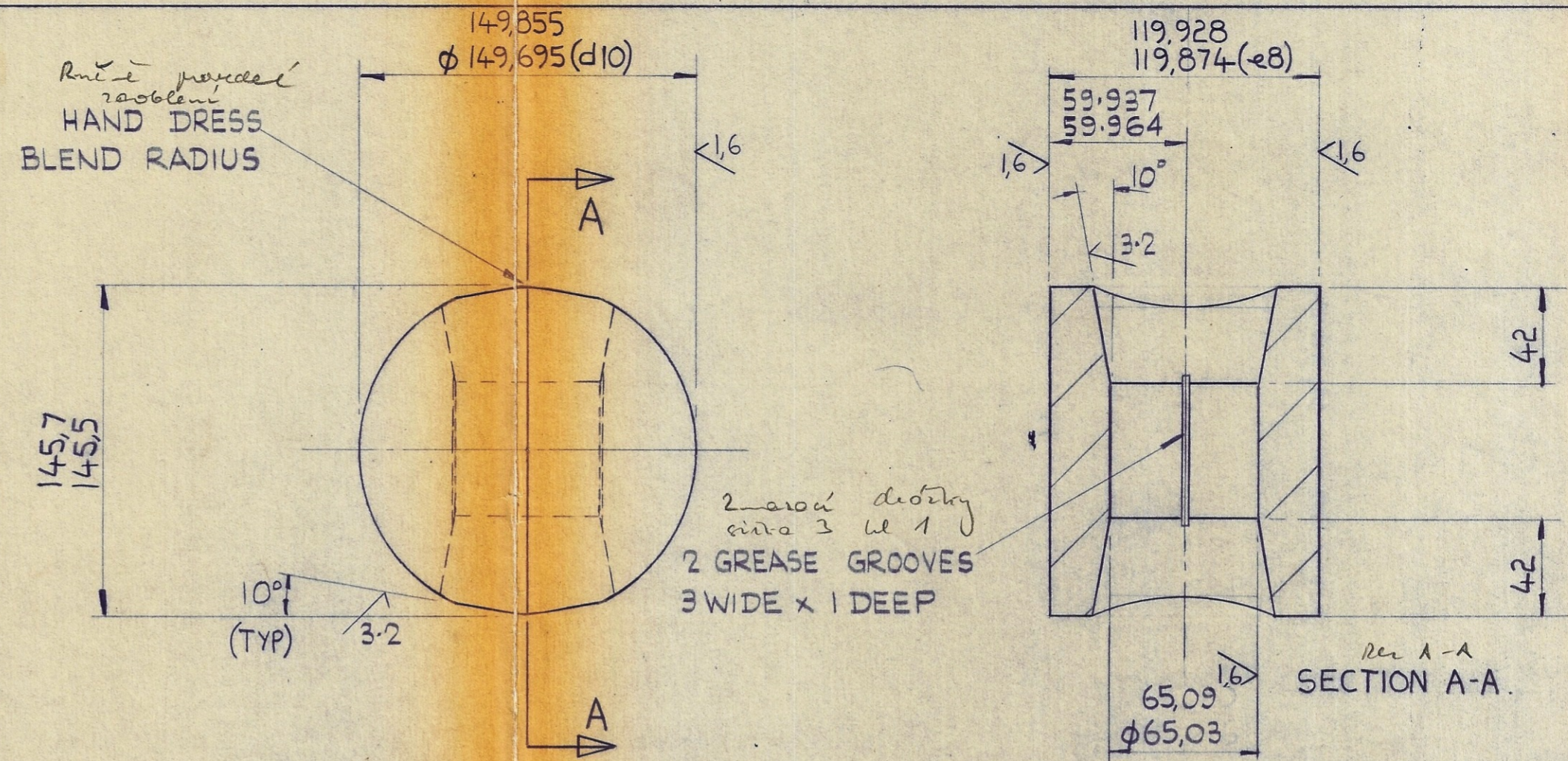

SCALE 1:2.5

REMOVE ALL SHARP CORNERS

207010

3

LETTER	
ZONE	
REVISION	
JOB NO.	
DATE & SIGN	

3	3	3	3	5	BONDED SEAL 1/2" BSP. 400-033-4490-02 AS MADE	KLINGERIT	0,007	DOWTY
3	3	3	3	4	BLANKING PLUG N° P.24. KEELAVITE	AS MADE	0,66	
3	-	3	-	3	BUSH (DRIVE MUFF)	L.B.2.	13,95	
-	-	-	3	3	BUSH (SMALL ROLL MUFF)	L.B.2	7,34	
-	-	-	3	3	SLEEVE (SMALL ROLL MUFF)	B.5.4360 GR43A	2,16	

NUMBER	ITEM	DESCRIPTION	MATL.	WEIGHT EACH kg	REMARKS		
14.6	14.5	7	5.3	14.4	6	UNTOLERANCED MACHINED DIMENSIONS TO BE WITHIN ±0.25 m/m	✓ DIMENSIONAL CHECK
A373	A373	A373	A373	A373	A373	© COPYRIGHT BY LOEWY ROBERTSON ENGINEERING COMPANY LIMITED This drawing is returnable on request and is not to be communicated to any third party nor must it be used except in relation to the single installation in connection with which it has been supplied.	WELD SYMBOLS TO B.S. 499
42	2.00	2.00	42	72	72	LOEWY ROBERTSON POOLE ENGLAND A DAVY ASHMORE COMPANY	SURFACE FINISHES IN MICRONS C.L.A. PROJECTION SCALE 1:1 & 1:2.5
TITLE THREE ROLL PIERCER. SMALL ROLL MUFF SLEEVE, BUSHES ОБЪЕКТ ПЕР МАЛЫ ВАЛЕЦ, ПОУЗДРА							
DATE SIGN	DRAWN (GED) R. SANTON.	APPROVED B.D.G.	OFFICE	DRAWING NO.	REV.		
18/7/77	CM/GED	DATE MAY 1977		200751			

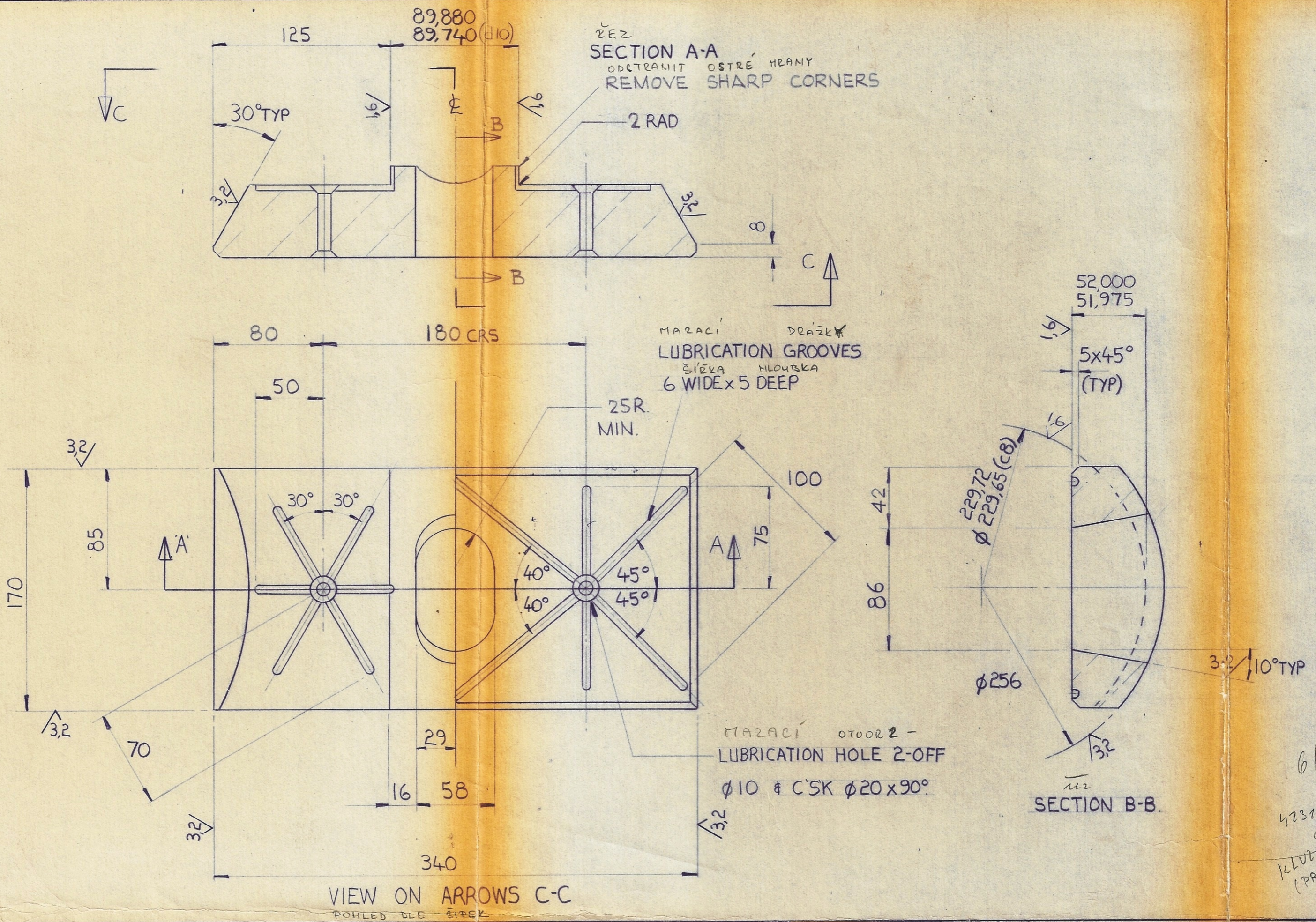

6 kum
423123
KLUZNY KAMEN
(PRO MALLE VALCE)
POS. 1

QTY	NO.	DESCRIPTION	MATL.	WEIGHT EACH kg	REMARKS
6	666	SLIPPER (DRIVE END AND LARGE ROLL)	P.B.2.	26,33	
		KLUZNY KAMEN (PRO VELKE VALCE)	423123		
3	333	SLEEVE (DRIVE END & LARGE ROLL)	BS 4360 GR 43A.	21,5	
		OBJIMKA (PRO VELKE VALCE)	1145B		
-	-	SLIPPER (SMALL ROLL)	P.B.2.	24,5	
		KLUZNY KAMEN (PRO MALLE VALCE)	423123		
14.6	A373	UNTOLERANCED MACHINED DIMENSIONS TO BE WITHIN ±0.25 m/m			✓ DIMENSIONAL CHECK
14.5	A373	COPYRIGHT BY LOEWY ROBERTSON ENGINEERING COMPANY LIMITED			WELD SYMBOLS TO B.S. 499
7	A373	This drawing is returnable on request and is not to be communicated to any third party nor must it be used except in relation to the single installation in connection with which it has been supplied.			SURFACE FINISHES IN MICRONS C.L.A.
5.3	A373	PROJECTION			SCALE 1:25 #1:5
14.4	A373	LOEWY ROBERTSON			
6	A373	POOLE ENGLAND			
222.5	200758	A DAVY ASHMORE COMPANY			
222.5	200758	TITLE			
222.5	200758	THREE ROLL PIERCER			
147	200758	SLIPPERS, LARGE MUFF SLEEVE			
147	200758	KLUZNE KAMENY, VELKA OBJIMKA			
DATE SIGN	ARRGT NO.	DRAWN	APPROVED	OFFICE	DRAWING NO.
18/77	200758	R SANTON (GED)	B.D.G.		200753
18/77	200758	CHECKED	DATE		
18/77	200758	CM/GED	MAY 1977		

DRAWING No.

REV.

200755

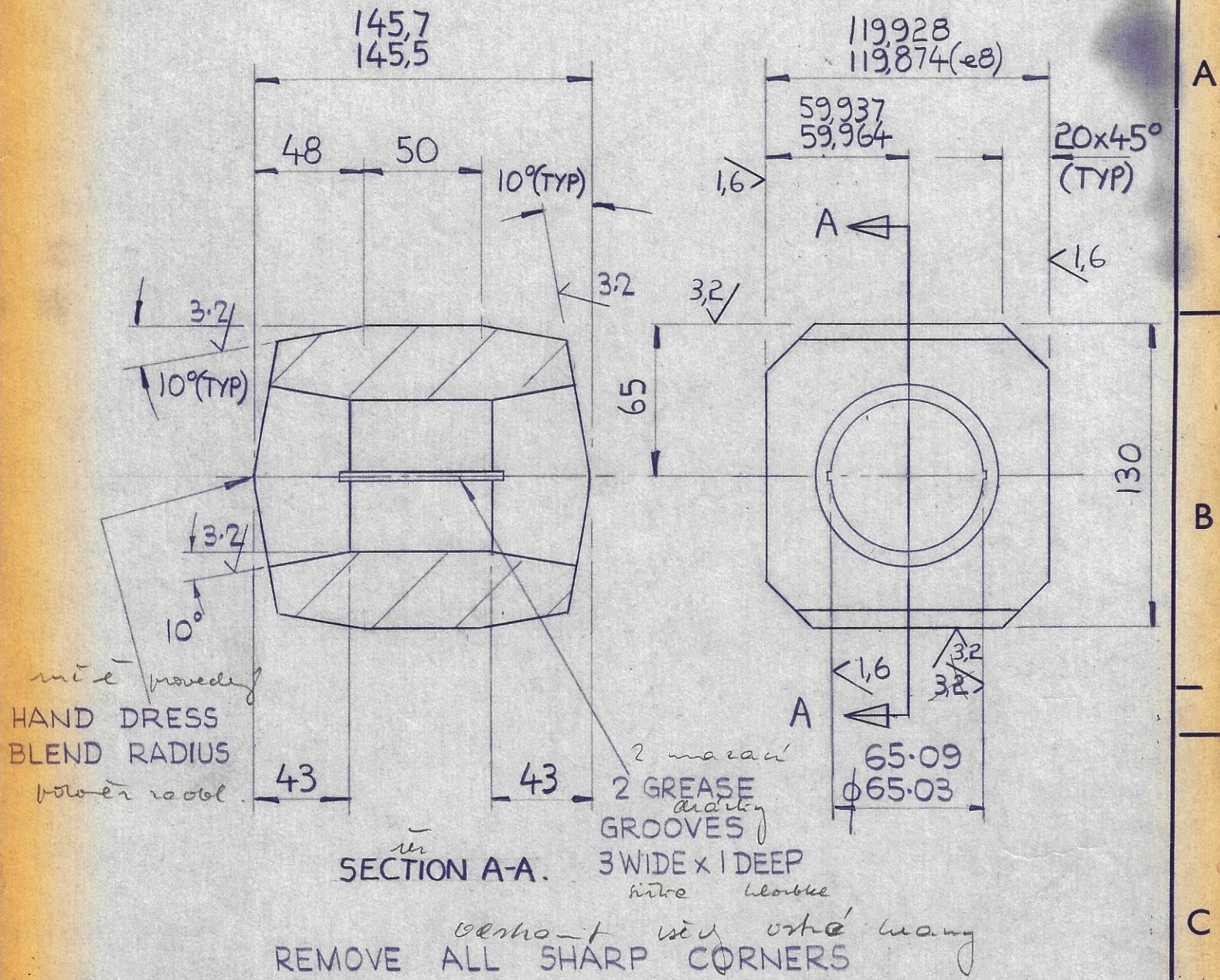

Form A3

2

3	3	-	-	2	BUSH (LARGE ROLL MUFF)	LB2.	15	
					POUZDRO (PRO OBJÍMKU VELKEHO VALCE)	423122		
-	-	3	3	1	LARGE ROLL SPADE END	EN26U	125	
					UNASEČ VŘETENE PRO VELKE VALCE	16540		

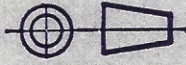
NUMBER	ITEM	DESCRIPTION	MATL.	WEIGHT EACH kg	REMARKS
14.5	7	14.6	5.3	UNTOLERANCED MACHINED DIMENSIONS TO BE WITHIN ±0.25 m/m	
A373	A373	A373	A373	COPYRIGHT BY LOEWY ROBERTSON ENGINEERING COMPANY LIMITED	
45	45	375	375	This drawing is returnable on request and is not to be communicated to any third party nor must it be used except in relation to the single installation in connection with which it has been supplied.	
200758	200758	200758	200758	 LOEWY ROBERTSON POOLE ENGLAND A DAVY ASHMORE COMPANY	
18/7/77	18/7/77	18/7/77	18/7/77	DIMENSIONAL CHECK <input checked="" type="checkbox"/> WELD SYMBOLS TO B.S. 499 SURFACE FINISHES IN MICRONS C.L.A. PROJECTION  SCALE 1:2.5	
TITLE THREE ROLL PIERCER 3VDS					
LARGE ROLL SPADE END, BUSH					
UNASEČ VŘETENE PRO VELKE VALCE POUZDRO					
DATE SIGN	DRAWN R. SANTON (GED)	APPROVED B.D.G.	OFFICE	DRAWING NO. 200755	REV.
DATE	CHECKED CM/GED	DATE MAY 1977			

PR-1424 Piercer Drive Coupling Copper-Alloy Bushes & Slipper

1. Drawing attached
2. Material: PB2
3. Chemical composition

Cu	Sn	Pb	Zn	Fe	Ni	P	Al	Si	Impurities
Rem.	11 ~ 13	0.5	0.3	0.15	0.5	0.15 Min	0.01	0.02	0.2

4. Material MTC or chemical testing report is required
5. CNC machine finish required as per dwg dimensions
6. Complete in all respect.